

1500 series



www.martekpower.com

Single, Dual, Triple Output DC/DC Converter



DESCRIPTIONS

The 1500 series 15 watts high performance DC/DC converters are cost effective solution to the high reliability and performance requirements of power distribution systems in applications ranging from high speed data communications equipment to industrial robotic systems. The 1500 series operates over 2:1 input voltage ranges of 9 to 18, 18 to 36 or 36 to 72VDC; providing single, dual and triple output combinations of 5, 12, 15, ± 5 , ± 12 , ± 15 , $5/\pm 12$ and $5/\pm 15$ VDC. All models are packaged in compact, low profile 2" X 2" X 0.4" metal cases.

OUTPUT CHARACTERISTICS

	Min	Typ	Max	Unit/Comments
Output Voltage Accuracy				
Single & Dual Outputs		± 1.0		% ¹
Triple Outputs - Primary		± 1.0		% ¹
- Auxiliaries		± 5.0		% ¹
Output Voltage Adjustment		± 5.0		% ¹
Voltage Balance:				
Dual Outputs		± 1.0		%; Equal Output Loads
Triple Outputs (Auxiliaries)		± 1.0		%; Equal Output Loads
Minimum Load		10%		Full Load
Line Regulation				
Single & Dual Outputs		± 0.5		% ²
Triple Outputs - Primary		± 0.5		% ²
- Auxiliaries		5.0		% ²
Load Regulation				
Single Outputs		± 0.3		% ³
Dual Outputs		± 1.0		% ³ ; Equal Loads
Triple Outputs - Primary		± 0.5		% ³
- Auxiliaries		± 5.0		% ³ ; Equal Loads
Ripple/Noise				
5V Outputs		75		mV p-p, Nom.Line FL, 20Mhz B.W. using 1 μ f bypass capacitor
12V and 15V Outputs		1		% of Vout
Short Circuit Protection				Continuous, Automatic Recovery
Transient Recovery Time		200		μ S to within 1% error band for 50% step load change
Temperature Coefficient		± 0.01		% per °C
Over Voltage Protection				See Model Selection Guide

FEATURES

- Synchronization
- 13.3W/In³ Power Density
- Efficiency to 87%
- UL 1950 Approved
- VDE / EN 60950 Approved
- >700,000 Hours MTBF
- 6 sided Continuous Shielding
- Output Voltage Trimming

INPUT CHARACTERISTICS

	Min	Typ	Max	Unit/Comments
Input Voltage Range				
12 VDC Input Models	9	12	18	VDC
24 VDC Input Models	18	24	36	VDC
48 VDC Input Models	36	48	72	VDC
Remote On / OFF Control				
Supply ON				5.5 VDC or Open Circuit
Supply OFF				0 VDC to 0.8 VDC
Logic Referenced to Negative Input				
Reverse Polarity Input Current			12	Amp
Input Filter				Internal Capacitor; External 10-20 μ F cap recommended across input pins
Input Fuse Rating				See Model Selection Guide

GENERAL CHARACTERISTICS

	Min	Typ	Max	Unit/Comments
Switching Frequency	100			kHz
Isolation Voltage	1000			VDC, 1 minute
Isolation Resistance	1000			Mohm, 500VDC
Isolation Capacitance		60		pF, 100kHz, 1Volt
MTBF (MIL-HBK-217F)	700			Thousand Hours, +25°C, Ground Benign

¹ = Output voltage at nominal line & FL

² = % Output voltage measured from min. input line to maximum

³ = Output voltage measured from FL to 10% Load

Martek Power reserves the right to change specifications without notice.

ENVIRONMENTAL SPECIFICATIONS

	Min	Typ	Max	Unit/Comments
Operating Temp. Range (Industrial)	-40		+71	°C; Ambient
Operating Temp. Range (Extended, "-X" suffix)	-55		+85	°C; Ambient
Storage Temp. Range	-55		+125	°C
Relative Humidity			95	% Humidity; non-condensing
Cooling				Free-Air Convection

PHYSICAL CHARACTERISTICS

	Unit/Comments
Case Size	2.0 X 2.0 X 0.4 inches (51.0 X 51.0 X 10.2 mm)
Case Material	Coated Metal with Non-Conductive Base
Shield Connection	
12V and 24V Input Models	Negative Input, Pin 3
48V Input Models	Positive Input, Pin 4
Flammability	UL94V-0
Weight	79 Grams

OUTLINE DRAWING

CASE A

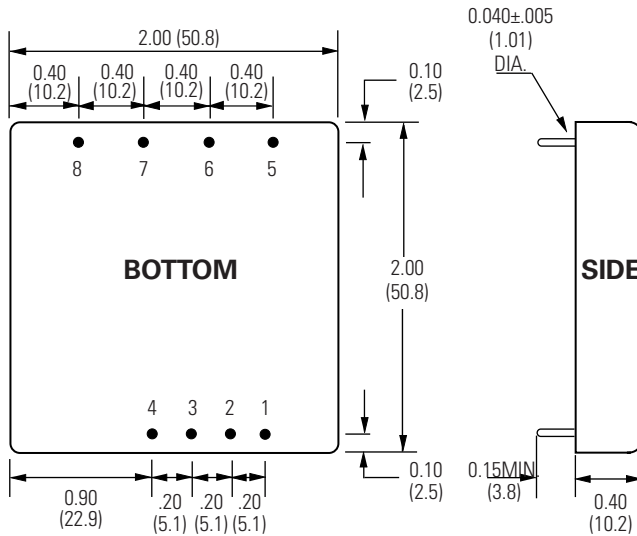

PIN OUT CHART; CASE A

Pin	Single	Dual	Triple
1	Remote On/Off	Remote On/Off	Remote On/Off
2	Sync	Sync	Sync
3	- Vin	- Vin	- Vin
4	+ Vin	+ Vin	+ Vin
5	Trim	Trim	- Vout (Aux)
6	- Vout	- Vout	Common
7	+ Vout	Common	+5V Vout
8	No Pin	+ Vout	+Vout (Aux)

CASE A1

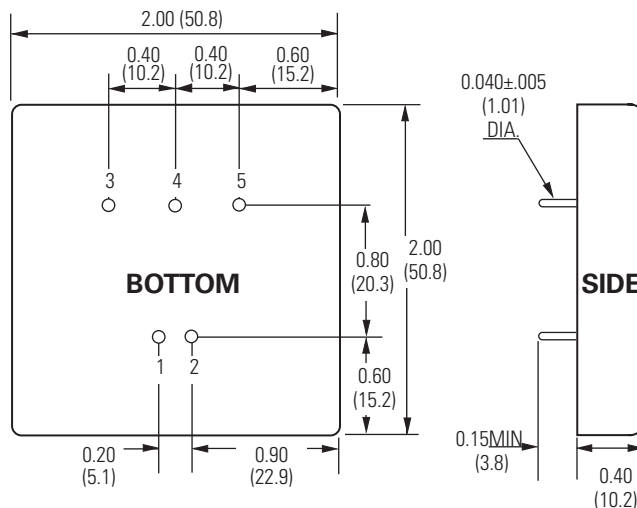

PIN OUT CHART; CASE A1

Pins	Single	Dual
1	+ Vin	+ Vin
2	- Vin	- Vin
3	+ Vout	+ Vout
4	Trim	Common
5	- Vout	- Vout

Notes:

1. Unless otherwise specified dimensions are in inches (mm).

Tolerances	Inches	mm
	X.XX = ±0.02	X.X = ±0.5
	X.XXX = ±0.010	X.XX = ±0.25

All specifications are typical at nominal input, nominal load and 25° C unless otherwise specified. External, low ESR, 10 microfarad (minimum) capacitor across output is recommended for operation.

How To ORDER

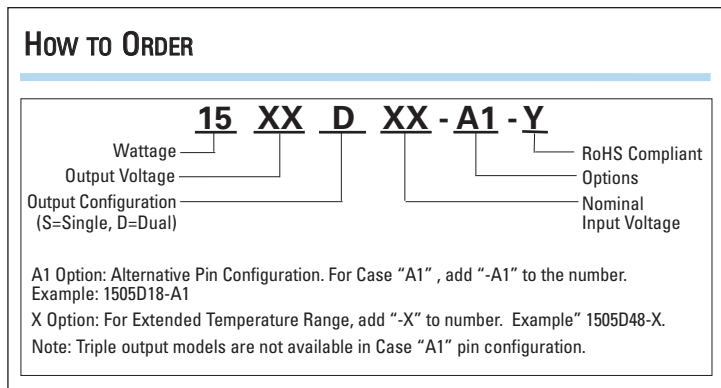

MODEL SELECTION CHART

Model	Nominal Input Voltage (VDC)	Output Voltage (VDC)	Full Load Output Current (mA)	No Load Input Current (mA)	Full Load Input Current (mA)	Output Over Voltage (VDC)	Fuse (A)	Efficiency @ FL (%)
1505S12	12	5	3000	45	1520	6.8	3.0	82
1512S12	12	12	1250	45	1520	15.0	3.0	82
1515S12	12	15	1000	45	1520	18.0	3.0	82
1505D12	12	±5	±1500	45	1562	±6.8	3.0	80
1512D12	12	±12	±625	45	1500	±15.0	3.0	83
1515D12	12	±15	±500	45	1500	±18.0	3.0	83
1505S24	24	5	3000	35	750	6.8	2.0	83
1512S24	24	12	1250	35	750	15.0	2.0	83
1515S24	24	15	1000	35	750	18.0	2.0	83
1505D24	24	±5	±1500	35	772	±6.8	2.0	81
1512D24	24	±12	±625	35	750	±15.0	2.0	83
1515D24	24	±15	±500	35	750	±18.0	2.0	83
1505S48	48	5	3000	32	370	6.8	1.0	84
1512S48	48	12	1250	32	375	15.0	1.0	83
1515S48	48	15	1000	32	375	18.0	1.0	83
1505D48	48	±5	±1500	32	381	±6.8	1.0	82
1512D48	48	±12	±625	32	376	±15.0	1.0	83
1515D48	48	±15	±500	32	376	±18.0	1.0	83
1505/12T12	12	5, ±12	1500, ±312	60	1561	6.8, ±15.0	3.0	80
1505/15T12	12	5, ±15	1500, ±250	60	1562	6.8, ±18.0	3.0	80
1505/12T24	24	5, ±12	1500, ±312	60	771	6.8, ±15.0	2.0	81
1505/15T24	24	5, ±15	1500, ±250	60	772	6.8, ±18.0	2.0	81
1505/12T48	48	5, ±12	1500, ±312	30	381	6.8, ±15.0	1.0	82
1505/15T48	48	5, ±15	1500, ±250	30	381	6.8, ±18.0	1.0	82

DERATING CURVES

MODEL 1500 - All models

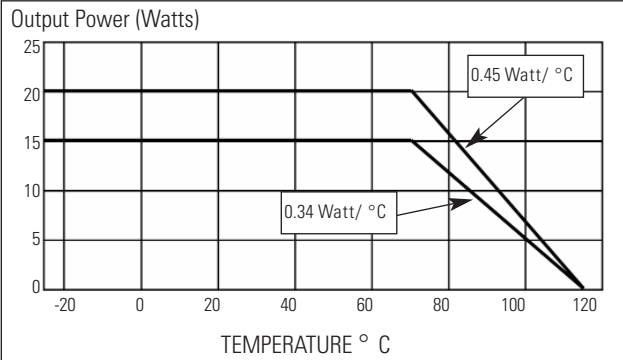

OUTPUT VOLTAGE ADJUSTMENT (1500 SERIES SINGLE OUTPUT)

The converter's output voltage may be trimmed to $\pm 10\%$ of the nominal output voltage.

TRIM UP

Trim output voltage up by connecting an external resistor between Pins 5 and 6. Use the following equation. Reference Table 1 for variable A.

$$\text{Radj-up} = \frac{A}{\Delta \%} - 24 \text{ (k}\Omega\text{)}$$

Example:

If we want to trim 5% up for 12V output units, where $A = 1.98$, $\Delta \% = 0.05$

$$\text{Radj-up} = \frac{1.98}{0.05} - 24 \text{ k}\Omega = 15.6 \text{ k}\Omega$$

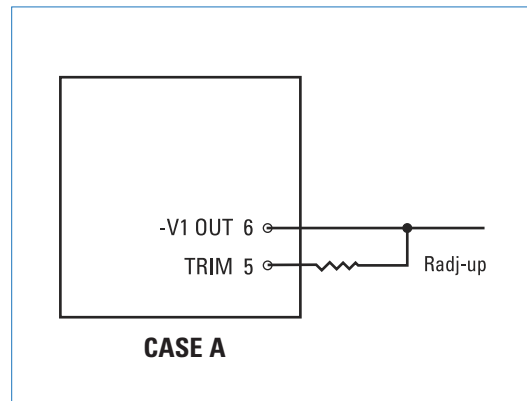

Table 1.

Output Voltage	A
3.3V	0.78
5V	1.24
12V	1.98
15V	2.07

TRIM DOWN

Trim output voltage down by connecting an external resistor between Pins 5 and 7. Use the following equation. Reference Table 2 for variable C and D.

$$\text{Radj-down} = \frac{C}{\Delta \%} - D \text{ (k}\Omega\text{)}$$

Example:

If we want to trim 4% down for 5V output units, where $C = 1.24$, $D = 26.5$, $\Delta \% = 0.04$

$$\text{Radj-down} = \frac{1.24}{0.04} - 26.5 \text{ k}\Omega = 4.5 \text{ k}\Omega$$

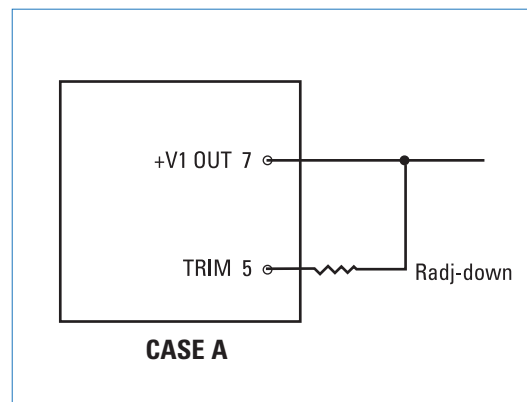

Table 2.

Output Voltage	C	D
3.3V	1.22	26
5V	1.24	26.5
12V	7.57	33.5
15V	10.3	36.4

OUTPUT VOLTAGE ADJUSTMENT (1500 SERIES DUAL OUTPUT)

The converter's output voltage may be trimmed to $\pm 10\%$ of the nominal output voltage.

TRIM UP

Trim output voltage up by connecting an external resistor between Pins 5 and 6. Use the following equation. Reference Table 1 for variable A.

$$\text{Radj-up} = \frac{A}{\Delta \%} - 24 \text{ (k}\Omega\text{)}$$

Example:

If we want to trim 5% up for 12V output units, where $A = 2.23$, $\Delta \% = 0.05$

$$\text{Radj-up} = \frac{2.23}{0.05} - 24 \text{ k}\Omega = 20.6 \text{ k}\Omega$$

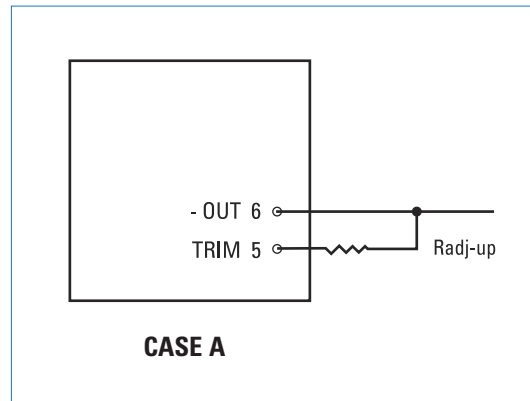

Table 1.

Output Voltage	A
5V	1.87
12V	2.23
15V	2.28

TRIM DOWN

Trim output voltage down by connecting an external resistor between Pins 5 and 8. Use the following equation. Reference Table 2 for variable C and D.

$$\text{Radj-down} = \frac{C}{\Delta \%} - D \text{ (k}\Omega\text{)}$$

Example:

If we want to trim 5% down for 5V output units, where $C = 5.63$, $D = 31.5$, $\Delta \% = 0.05$

$$\text{Radj-down} = \frac{5.63}{0.05} - 31.5 \text{ k}\Omega = 81.1 \text{ k}\Omega$$

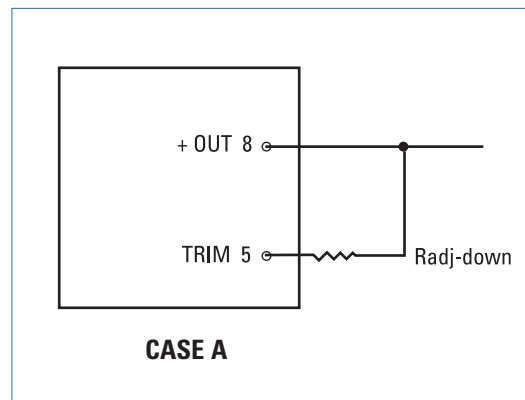

Table 2.

Output Voltage	C	D
5V	5.63	31.5
12V	19.3	45.5
15V	25.1	51.4